



GORILLA DECK® G3 INSTALLATION GUIDELINES

Gorilla Deck G3 is a wood-grain embossed PVC deck board system with a water-shedding design. The patented (U.S. Patent No. 6,324,796) interlocking deck boards are designed to channel water between the boards and discharge it at the edge of the deck. The Gorilla Deck G3 system may also be installed as a conventional deck where the system's water-shedding features are not a requirement. Gorilla Deck G3 is NOT intended for roofing applications. The Gorilla Deck system is manufactured under a stringent quality control program, and when properly installed will give you years of enjoyment with low maintenance.

WATER-SHEDDING FEATURES:

Preparation of the deck substructure and proper installation of the deck boards are critical to achieving the G3 system's water-shedding capacity. For proper performance of the G3's water-shedding features:

- The deck boards are to be installed with a **slight pitch** (at least 1/8" per 8' of board length) to direct the water away from the adjoining structure.
- **Continuous lengths** of deck board must be installed. End-splicing of boards will provide a gap for water to penetrate the system and leak through. The deck boards are produced in lengths of up to 24 feet. Care must also be taken when cutting openings in the deck board surface for guardrail post installation. Any area cut into the deck board could leak unless properly sealed.
- The deck system must be **properly flashed** to prevent water from entering the space between the ledger board and the adjoining structure.
- Rain water will drain to the edges of the deck boards. At this time, the G3 system does not include a gutter system to collect the channeled water. Depending on the installation, readily available standard gutter and downspout combinations may be an option for collecting the channeled water.

REQUIRED TOOLS AND MATERIALS:

- Safety glasses
- Power drill with screwdriver bit
- Measuring tape
- Level (preferably 48" or longer)
- Saber saw/jig saw for cutting openings for guardrail posts
- Power saw
- Flashing
- Silicone caulk and caulking gun
- Rubber mallet (with non-marking face)

★ Stainless steel, self-tapping pan-head screws (1 1/2" #8 and 3/4" #6) ★

SUBSTRUCTURE PREPARATION:

Prior to installation, consult your **local building department** to address applicable building codes, including codes pertaining to the deck substructure, attachment to the adjoining building, and installation of guard railing and stairs.

The deck substructure, usually wood framing, is an important part of proper installation. Homeland Vinyl recommends 16" joist spacing, however 24" spacing can be used where boards are placed perpendicular to joists.

The substructure must be level, in that it must not have irregular high or low spots across the joists. In order to shed water, the substructure will require a minimum pitch of 1/8" per 8' of board length. The pitch must be oriented to create positive drainage away from the adjoining building in the lengthwise direction of the deck board. Any high or low spots can cause the deck boards to separate,

causing a potential area for leaks.

The deck ledger board must be properly flashed in order to prevent water from affecting the adjoining building, and to make the best use of the G3 system's water-shedding features. In addition to the typical flashing installed over the ledger board, supplemental flashing should be installed behind the house siding and over the top of the adjoining deck boards. Caulk should be applied to the angle flashing to create a seal to the top of the deck boards and to prevent water from entering the gap between the deck boards and the adjoining building. **(See figure 1)**

NOTE: a full description of deck flashing installation is beyond the scope of these guidelines. Each installation is unique, and the installer is responsible for complying with applicable codes and good building practices.

(Figure 1 - Flashing detail)

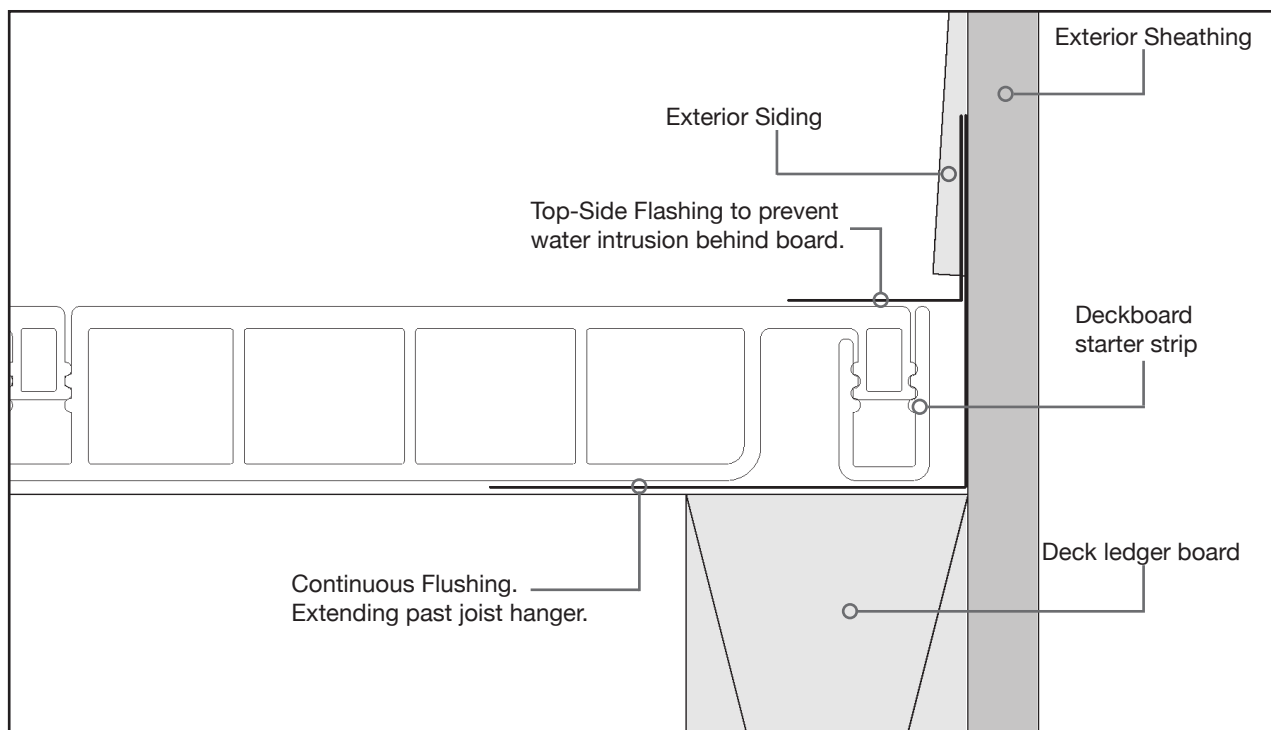

INSTALLATION:

Install the **starter strip** using a 1-½", #8 self-cutting stainless steel pan-head screw at each joist. The long edge of the starter strip should face the outside edge of the deck substructure. The screws are inserted in the hollow chamber of the starter strip. Apply caulk to the screw heads to seal against water infiltration. **(See figure 2)**

(Figure 2 - Starter strip)

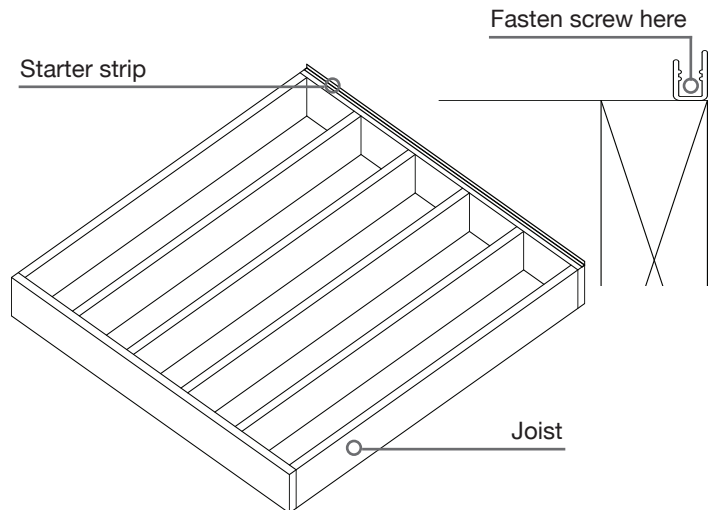

Place the first deckboard into the starter strip. The deckboard must be locked in place by walking it down or tapping with a (non-marking) rubber mallet. Secure the deck board using 1-½", #8 self-cutting stainless steel pan-head screws at each joist. Ensure that the screws are inserted into the flange at the edge of the deckboard, NOT the hollow interlocking channel. Screws placed within the channel can cause water leaks. **(See figure 3)**

(Figure 3 - First deck board)

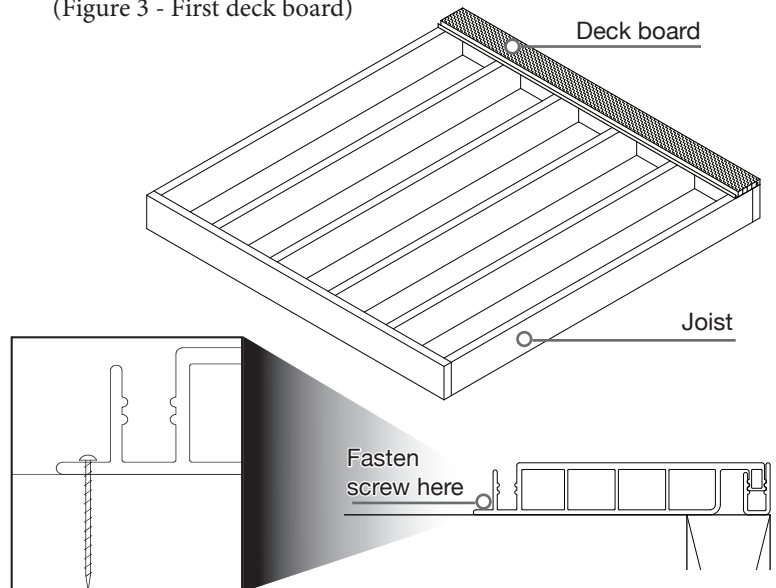

Continue the same method with the following deck boards, interlocking the boards and attaching them with screws until the deck surface is complete. **(See figure 4)**

(Figure 4 - Additional deck boards)

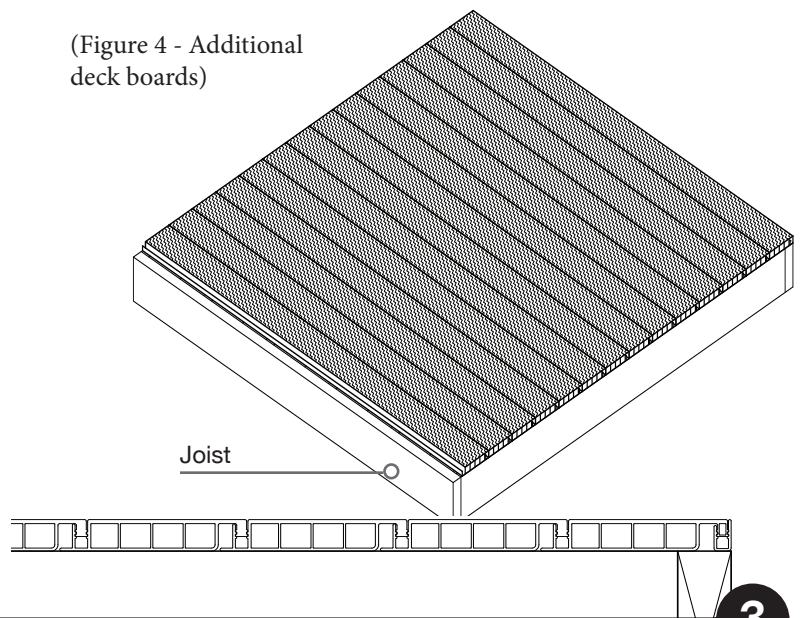

The final deck board may require ripping to the appropriate width according to the dimensions of the deck substructure. The interlocking chamber and nailing flange should be trimmed from the final deck board to allow proper fitting of the trim channel.

(Figure 5 - Flush cut deck board)

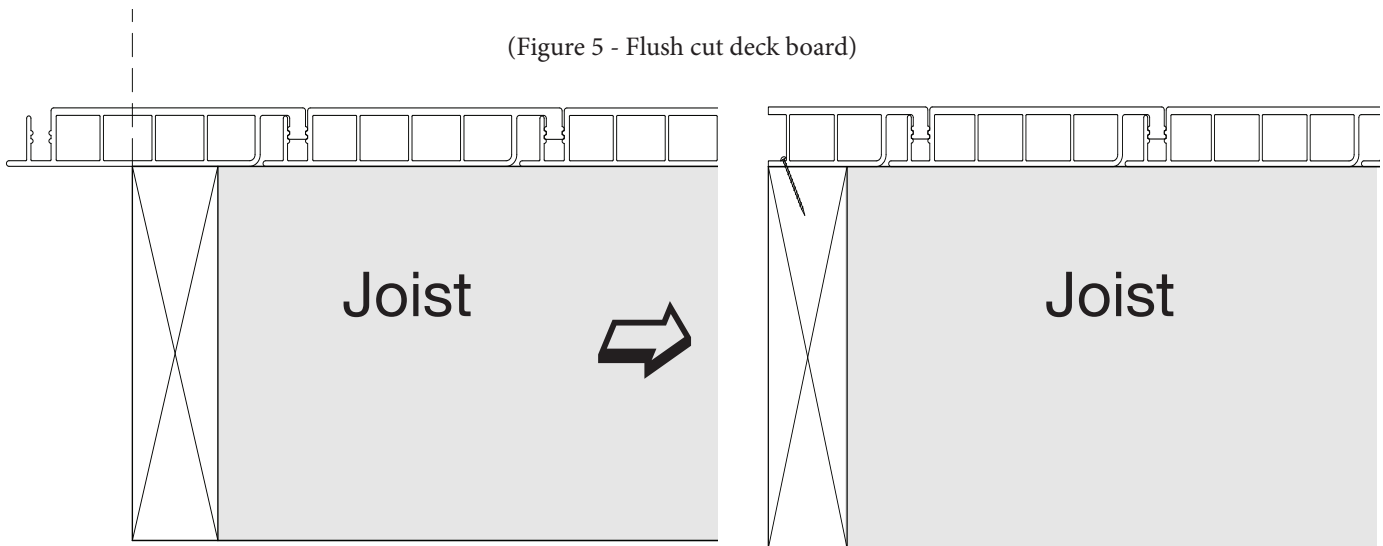

(Figure 6 - Overhanging deck board)

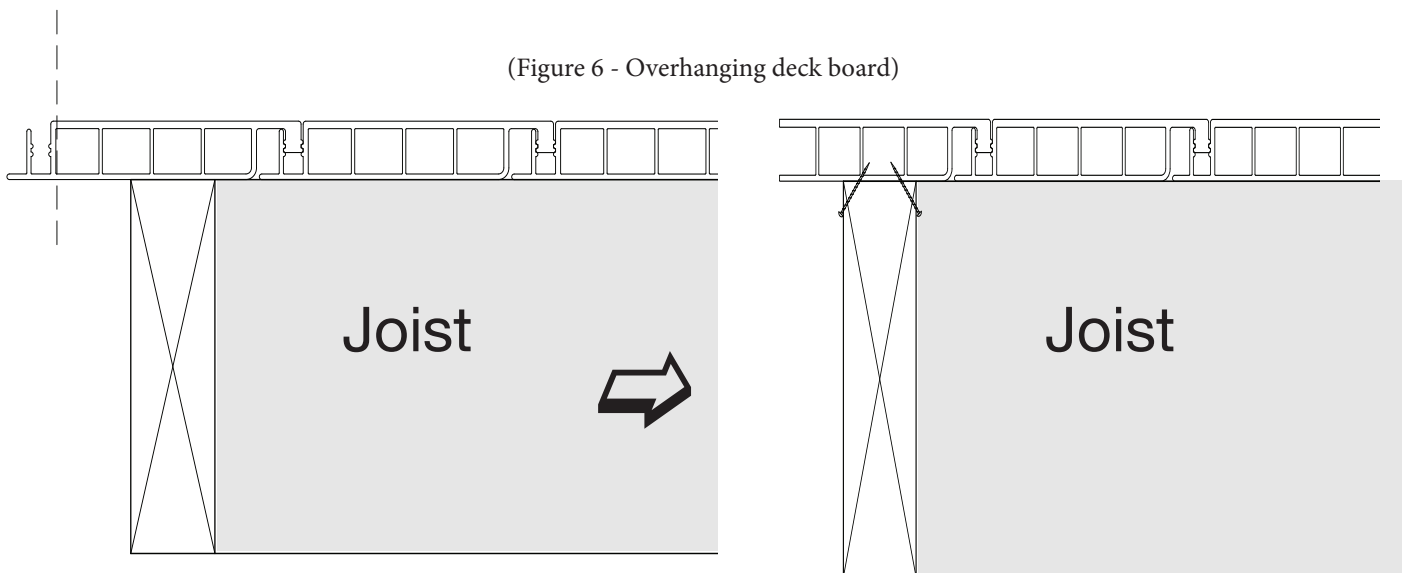

The Gorilla Deck G3 system has two styles of edge trim channels: the C-shaped “Finish Trim” and the L-shaped “Fascia Trim”, as well as an I-shaped “Splice Trim”. The Finish Trim piece is used along the edges of the deck boards where the boards overhang the edge of the substructure rim joists by approximately 1 ½” (**See figure 7**). The Fascia Trim is used where the deck boards are cut flush with the substructure rim joists. (**See figure 8**). The Splice trim is used where deck boards meet. (**See figure 9 - on next page**). The trim channels are thinner than the deck boards, and must be allowed to move slightly to account for thermal contraction and expansion. If such allowance is not made, the trim pieces may wrinkle or warp due to thermal expansion.

When installing the Deck Trim channels, it is important to:

- pre-drill a double-hole or slot for the screw attachment,
- install screws at no less than a 4 foot interval, and
- install the screw so that it is snug, but not tight.
- Do NOT apply sealant to the finish trim or fascia trim channels. The channeled rain water must be allowed to discharge from the end of the deck boards.

(Figure 7 - Finish trim detail)

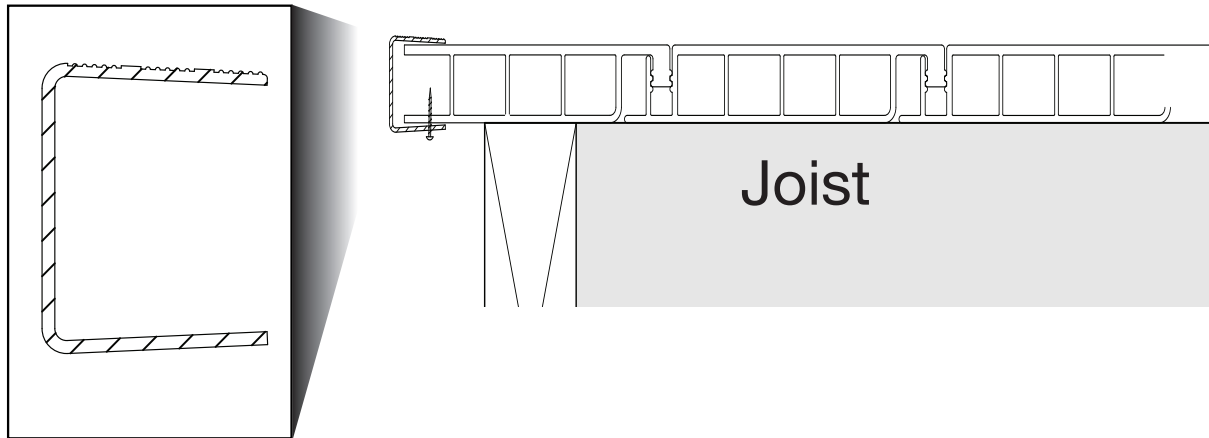

(Figure 8 - Fascia trim detail.)

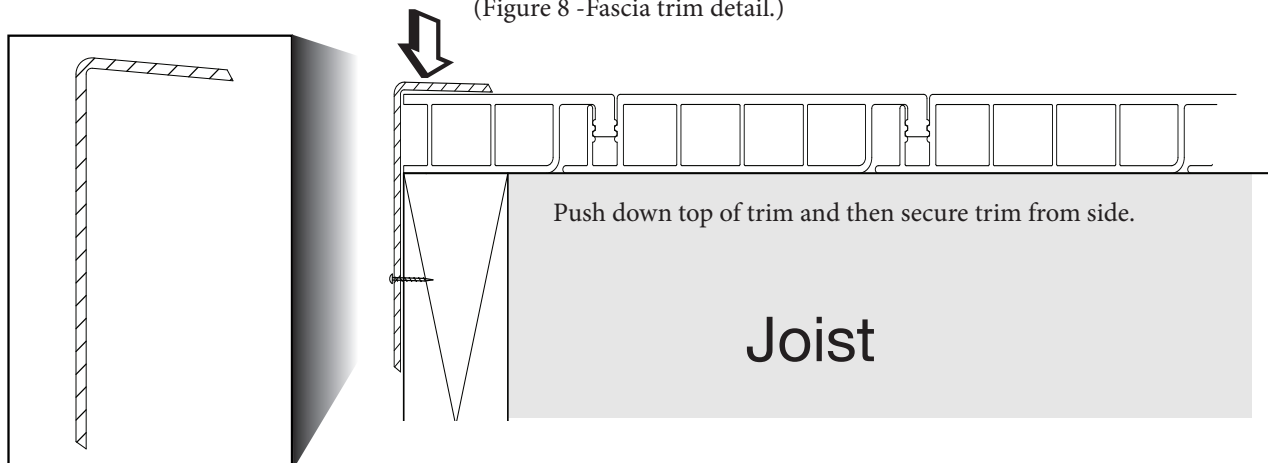

As noted previously, the Gorilla Deck G3 system is designed to be installed as a series of continuously interlocked deck boards in order to provide the water-shedding feature. In situations where deck boards come together without a Gorilla Deck interlock (i.e., mitre cut or butt joint), the Gorilla Deck boards may be spliced, but the water-shedding features are not applicable at any splice.

In an installation requiring a splice, it is recommended that the splice be installed at a double joist. The splice should be located at the high point of the sloping substructure, so that water will drain away from the spliced connection. When installing the splice channel, silicone sealant should be applied on the upper and lower deck board surfaces as well as the ends of the interlocking channel on each deck board.

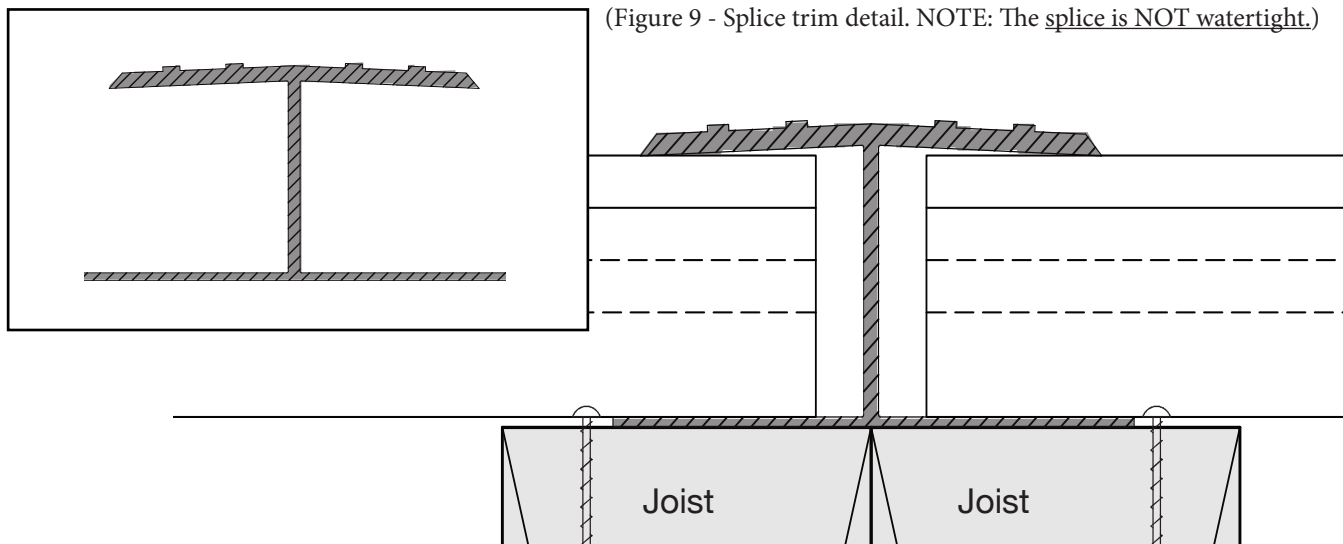

GUARDRAIL POSTS:

It is the installer's responsibility to ensure that a deck's **guardrail system** complies with applicable **building codes**. If the guardrail installation includes posts that extend through the deck surface:

- Carefully cut openings in the deck boards to allow the posts to fit,
- Apply caulk between the edges of the openings and the posts,
- Install trim pieces at the post base to conceal the openings in the deck boards.

In order to maximize the water-shedding features of the system, post openings should avoid breaching the deck boards' water-shedding channels. If disruption of the channel is unavoidable, some leakage may occur at the rail post opening.

STAIR TREAD INSTALLATION:

Sept. 18, 2014

Gorilla Deck can be used in a stair tread in a two-span application with stringers no more than 12" apart. For stair tread installation, install the starter strip next to the riser of the stair stringers. Install the first deck board as on a deck installation.

Trim the second deck board to the appropriate step run length according to the applicable building code. The trimmed edge of the deck board should be secured to the stair stringer using appropriate length screws.

Cover the cut edge of the stair tread deck board using Finish Trim. Secure the Finish Trim in place using PVC compatible adhesive on the top and bottom of the deck board and 3/4" #6 pan head stainless steel screws through the bottom of the finish trim into the deck board.

Repeat for each stair tread.

Gorilla Deck G3 is not intended to be installed over a solid surface. Due to the interlocking water shedding design, Gorilla Deck G3 needs an open air environment beneath the structure to prevent trapped heat from warping the deck boards.

RECOMMENDATIONS:

Darker colors, such as Mocha Walnut, may become hot to the touch after prolonged exposure to direct sunlight. This effect can be mitigated with umbrellas, awnings or other shade producing fixtures.

PVC deck boards may be cleaned with mild soap and water. For stubborn marks, a cleaning pad such as Magic Eraser can be used. Cleaning products should be tested in an inconspicuous area before being applied on the full deck surface.

DOs & DON'Ts:

DO: Install Gorilla Deck G3 on wooden joists.

DO NOT: Install directly on plywood sheeting, concrete or other plane surface.

DO NOT: Install Gorilla Deck G3 as a Roof.

DO NOT: Expose Gorilla Deck G3 to unusual or excessive heat sources (e.g., outdoor fire pits, grills, glass window or door reflections) or install adjacent to areas that may absorb heat such as concrete, asphalt or dark-colored gravels.

DO NOT: paint the PVC deck boards.

DO NOT: Use spray-on sunscreen products on Gorilla Deck G3. Spray-on sunscreen products may cause discoloration of the PVC deck board. It is recommended that spray-on sunscreen be applied either indoors, off the deck, or in such a manner that oversprayed product will not come in contact with the deck.

DO NOT: use rubber mats on Gorilla Deck, as they may discolor the deck surface.

The examples and instructions in this document are for illustration purposes only. Any construction or installation of these products must be in accordance with all local building codes. The installer assumes all risks associated with the installation of these products including, without limitation, improper installation, misuse, neglect, improper handling or alterations to these products.

NOTES:
